

CONTENTS

GENERAL INTRODUCTION		
Part 1		
PROJECTILES, PROPELLANTS, AND PROJECTILE FUZES		
Chapter 1 — Projectiles	<i>Page</i>	
Introduction	7	
3-inch projectiles	25	
4-inch projectiles	30	
5-inch projectiles	33	
6-inch projectiles	47	
7-inch projectiles	52	
8-inch projectiles	54	
12-inch projectiles	57	
14-inch projectiles	59	
16-inch projectiles	62	
20-mm projectiles	65	
40-mm projectiles	70	
1.1-inch projectiles	72	
"Pounder" projectiles	73	
7.2-inch projectile	74	
Chapter 2 — Cartridge Cases and Bag Charges	75	
Introduction	75	
Cartridge case specifications	78	
Bag ammunition	79	
Existing service rounds	80	
Chapter 3 — Projectile Fuzes	89	
Introduction	89	
Point detonating fuzes	91	
Nose time fuzes	103	
V.T. fuzes	112	
Auxiliary detonating fuzes	119	
Base fuzes	124	
Chapter 4 — Primers and Tracers	137	
Introduction	137	
Primers	138	
Tracers	141	
Part 2		
ROCKETS AND ROCKET FUZES		
Chapter 5 — Rocket Bodies	145	
Introduction	145	
Army rockets (service)	150	
Army rockets (developmental)	157	
Navy rockets	161	
Chapter 6 — Rocket Fuzes	183	
Introduction	183	
Army nose fuzes	183	
Army base fuzes (service)	187	
Army base fuzes (experimental)	189	
Navy nose fuzes	191	
Navy base fuzes	215	
Navy auxiliary detonating fuze	224	
Part 3		
PYROTECHNICS		
Chapter 7 — Introduction	227	
Chapter 8 — Aircraft Pyrotechnics	229	
Pistol and hand-size signals	229	
Drift signals	236	
Navy flares	238	
Depth charge and slick markers	249	
Army flares	251	
A.A. target flares	255	
Target identification bombs	257	
Smoke streamer bombs	261	
Photoflash bombs	262	
Chapter 9 — Ground Pyrotechnics	265	
Signals	265	
Flares	273	
Chapter 10 — Shipboard Pyrotechnics	281	
Surface vessel items	281	
Submarine pyrotechnics	291	
Part 4		
GRENADES		
Chapter 11 — Hand Grenades	301	
Chapter 12 — Rifle Grenades	311	
Introduction	311	
Rifle grenades (listing)	312	
Chapter 13 — Projection Adapters	316	
Chapter 14 — Tree Suspension Device	319	
Part 5		
LAND MINES AND FIRING DEVICES		
Chapter 15 — Land Mines	321	
Introduction	321	
Anti-tank mines	321	
Anti-personnel mines	328	
Trip flares for mine fields	330	
Firecracker	332	
Chapter 16 — Fuzes and Firing Devices	333	

Weight of filling, pounds	0.28
Weight of loaded projectile, pounds	13
Charge/weight ratio	2.15%
Cartridge case	Mk 2
Primer	Mk 10 Mod 9
Tracer	Integral in fuze
Fuzes	Base Ignition Fuze Mk 8 Mod 4

Base Ignition Fuzes Mk 8 Mod 5 or Mk 2 Mod 9 (without tracers) may be used in this projectile, but the Mk 8 Mod 4 with integral tracer is preferred.

This round may also be issued B.L. & P. or B.L. & T. with the Tracer Mk 7 for target practice.

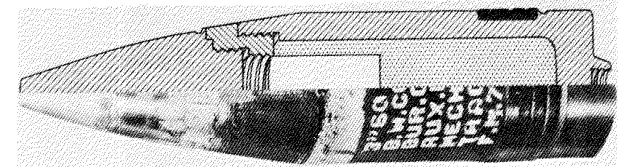

Figure 21. 3-inch A.A. Mk 23 Mods 1—3

3-inch A.A. Mk 23 Mods 1, 2, and 3 (Obsolete)

Guns used in	3"/50
Over-all length, inches	
With nose fuze	12.13
Without nose fuze	8.11
Diameter of base, inches	2.98
Distance base to band, inches	1.80
Width of band, inches	0.70
Diameter at bourrelet, inches	2.98
Filling	Cast TNT
Weight of filling, pounds	0.74
Weight of loaded projectile, pounds	13.05
Charge/weight ratio	5.67%
Cartridge Case	Mk 3, Mk 3 Mods 2 and 3
Primer	Mk 14
Tracer	Mk 4
Fuzes	
Nose Mk 22 and Mods 1 through 5 (M.T.F.)	
Mk 30 and Mods 1, 2, 3, (P.D.F.)	
Mk 51 and Mods (M.T.F.)	
Auxiliary Detonating Fuze	
Mk 17 and Mods or	
Mk 46	
Mk 54 Mod 0	

Production of this projectile has been discontinued.

3-inch A.A. Mk 26 Mods 1 and 2

Guns used in	3"/28
Over-all length, inches	
With nose fuze	12.13
Without nose fuze	8.11
Diameter of base, inches	2.97
Distance base to band, inches	1.80
Width of band, inches	0.70
Diameter at bourrelet, inches	2.98
Filling	Cast TNT
Weight of filling, pounds	0.74
Weight of loaded projectile, pounds	12.95
Charge/weight ratio	5.71%
Cartridge Case	Mk 2
Primer	Mk 10 Mod 9
Tracer	Mk 4
Fuzes	
Nose Mk 22 and Mods 1 through 5 (M.T.F.)	
Mk 51 all Mods (M.T.F.)	
Auxiliary Detonating Fuze	
Mk 17 and Mods or	
Mk 46	
Mk 54 and 0	

The Auxiliary Detonating Fuze Mk 54 is replacing the Mk 17 and the Mk 46 in all assemblies.

*OP 2213 Pyrotechnics & Misc. Explosives- SAMPLE
(reduced size)-*

CONTENTS

<i>Chapter</i>	<i>Page</i>
1. FLARES	
Introduction	1
Aircraft Parachute Flare Mk 4 Mods 2, 3, 4, and 5.....	6
Aircraft Parachute Flare Mk 5 Mods 3, 4, 5, 6, 7, 8, 9, and 10.....	8
Aircraft Parachute Flare Mk 6 Mods 3, 4, 5, and 6.....	9
Aircraft Parachute Flare Mk 8 Mods 0, 1, and 2.....	11
High Altitude Parachute Flare Mk 20 Mod 0.....	14
Trip Parachute Flare M48.....	15
Trip Flare M49.....	19
Trip-Wire Flare Mk 1 Mod 0.....	21
2. MARKERS	
Introduction	24
Depth Charge Markers Mk 1 Mods 2 and 3.....	25
Depth Charge Marker Mk 2 Mod 0.....	28
Night Drift Signal Mk 5 Mod 4.....	30
Aircraft Float Light Mk 6 Mod 2.....	31
Marine Marker Mk 7 Mod 2.....	33
Marine Marker Mk 8 Mod 0.....	34
Marine Marker Mk 9 Mod 0.....	35
Slick Marker Cartridge AN-Mk 1 Mod 0.....	36
Slick Marker AN-M59.....	39
3. SIGNALS	
Introduction	40
Aircraft Red Star Parachute Signal M11.....	41
Aircraft Double-Star Signals AN-M37 to AN-M42 Series and AN-M37A1 to AN-M42A1 Series.....	43
Aircraft Single-Star Signals AN-M43 to AN-M45 Series and AN-M43A1 to AN-M45A1 Series.....	44
Aircraft Signals AN-M53 to AN-M58 Series and AN-M53A1 to AN-M58A1 Series.....	47
Distress Smoke Hand Signal Mk 1 Mod 0 and AN-Mk 1 Mod 1.....	48
Day and Night Distress Signal Mk 13 Mod 0.....	51
Distress Signal AN-M75.....	53
Aircraft Emergency Identification Signal Mk 6 Mod 0.....	54
Aircraft Emergency Identification Signal Mk 7 Mod 0.....	56
Flash and Sound Signal M74.....	59
Ground Signals M17A1 to M22A1 Series and M17A1B2 to M22A1B2 Series.....	60
Illuminating Shell M83.....	62

*OP 2213 Pyrotechnics & Misc. Explosives- SAMPLE
(reduced size)-*

<i>Chapter</i>	<i>Page</i>
3. SIGNALS (Cont'd)	
Navy Light Mk 1 Mods 0, 1, and 2.....	64
Pistol Rocket Signal Mk 1 Mods 0, 1, and 4.....	65
Pistol Rocket Signal (Smoke) Mk 2 Mods 0 and 1.....	67
Pistol Rocket Signal (Shower, Single Burst) Mk 3 Mod 0.....	69
Red Star Parachute Distress Signal M131.....	71
Submarine Emergency Identification Signal Mk 3 Mods 1, 2, and 3.....	73
Submarine Float Signals Mk 2 Mods 0, 1, and 2.....	77
Torpedo Float Signal Mk 21 Mod 1.....	81
Very Signal Light Mk 2 Mod 0.....	84
One-Inch Salute Mk 1 Mod 0 (also labeled 1¼-inch Salute Mk 1 Mod 0).....	85
4. SURFACE PROJECTORS	
Introduction	86
Projector Mk 13 Mod 0.....	86
Pyrotechnic Pistol AN-M8.....	88
Rocket Signal Pistol Mk 1 Mod 0.....	89
Very Signal Pistol Mk 5 Mod 0.....	91
5. PHOTOFLASH BOMBS	
Introduction	96
100-Pound Photoflash Bomb AN-M46.....	96
Photoflash Bombs M120 and M120A1.....	101
Photoflash Bomb M122.....	105
6. PHOTOFLASH BOMB FUZES	
Introduction	108
Mechanical Time Fuze AN-M146A1.....	115
Mechanical Time Fuzes AN-M147 and AN-M147A1.....	117
7. AIRCRAFT PHOTOFLASH CARTRIDGES	
Introduction	120
Photoflash Cartridge M112.....	121
Photoflash Cartridge M123.....	121
8. MISCELLANEOUS EXPLOSIVE ITEMS	
Introduction	123
Aircraft Engine Starter Cartridge, Type II.....	123
Personnel Ejection Catapult Cartridge Mk 1 Mod 0.....	125
Personnel Ejection Catapult Cartridge Mk 2 Mod 0.....	127
Personnel Ejection Catapult Cartridge M28A1.....	128
Personnel Ejection Catapult Cartridge M36A1.....	129
Bomb Ejector Cartridge Mk 1 Mod 2.....	129
Bomb Ejector Cartridge Mk 2 Mod 0.....	132

**OP 2213 Pyrotechnics & Misc. Explosives- SAMPLE
(reduced size)-**

<i>Chapter</i>	<i>Page</i>
8. MISCELLANEOUS EXPLOSIVE ITEMS (Cont'd)	
Aircraft Canopy Remover Cartridge M29A2.....	133
Aircraft Canopy Remover Cartridge M31A1.....	134
Primer (Electric) Mk 25 Mod 0.....	134
Signals (Underwater Sound) Mk 22 Mods 0 and 1.....	137
Mine-Sweeping Cutter Mk 13 Mod 0.....	140
9. DISPOSITION OF PYROTECHNICS AND MISCELLANEOUS EXPLOSIVE ITEMS	
General.....	145
Items requiring Burning.....	145
Items requiring Dumping.....	145
Items which may be Burned or Dumped.....	146
10. SAFETY PRECAUTIONS.....	147

**OP 2213 Pyrotechnics & Misc. Explosives- SAMPLE
(reduced size)-**

OP 2213

Very Signal Light Mk 2 Mod 0

Mk	2		
Mod	0		
Drawing No.	344562		
Length (in.)	2.43		
Maximum Diameter (in.)	0.88		
Weight (oz)	1.1		
Burning Time (sec)	6		
Candlepower			
Green	600		
Red	300		
White	250		
Height of Rise (ft)	200		
Ignition Charge			
Type	Black powder		
Weight (grains)	0.6		
Propellant			
Type	Black powder		
Weight (grains)	10		
Shipping Container			
Number of Rounds	400	450	1000
Type	Metal	Metal	Metal
Weight (lb)	49	52	100

shell with the pyrotechnic star taking the place of the shot or projectile. The case, base, and primer are of commercial grade such as that used for shotgun shells, with a charge of black powder as the propellant. A hard felt wad protects the pyrotechnic star from the shock of the explosion of the propellant. The star charge is a cylinder of pyrotechnic material reinforced with wire and wrapped with quickmatch.

Operation. Very Signal Lights Mk 2 Mod 0 are projected by Very Signal Pistol Mk 5. When the firing pin of the pistol strikes the primer of the cartridge-type signal, the propelling charge is ignited and the pyrotechnic star charge is projected. The quickmatch wrapping of the star is ignited by the explosion of the propelling charge which, in turn, ignites the star.

Packaging and Identification. The paper case of the cartridge is the same color as the star, and the closing wad is marked with the color of the star. Night identification of star color is provided by the closing wad, which is ridged for a red star, smooth for a green star, and has a conical projection in the center for a white star.

Handling, shipping, stowage, and safety precautions for this signal are the same as for small arms ammunition.

General. Very Signal Light Mk 2 Mod 0 is a cartridge-type signal used primarily for distress signaling. A white, red, or green colored star is projected by this cartridge.

The cartridge resembles a 10-gauge shotgun

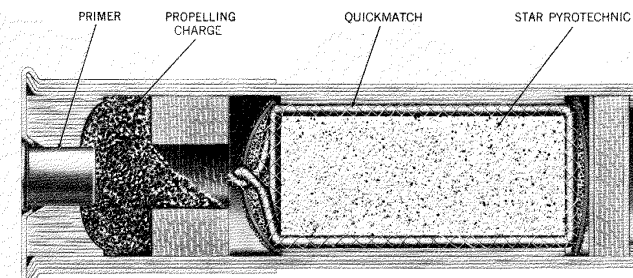

Figure 3.41—Very Signal Light Mk 2 Mod 0, Cross Section.

*OP 2238 Identification of Ammunition - SAMPLE
(reduced size)-*

CONTENTS

<i>Chapter</i>	<i>Page</i>	<i>Chapter</i>	<i>Page</i>
1. INTRODUCTION.....	1	2. NAVY GUN AMMUNITION—Con.	
Purpose.....	1	Cartridge Cases for Catapult	
Methods.....	1	Impulse Cartridges.....	19
Standard Lettering Information.....	1	Cartridge Cases for Torpedo	
Standard Abbreviations and		Impulse Cartridges.....	19
Symbols.....	3	Cartridge Cases for Saluting	
Navy Chemical Warfare Am-		Cartridges.....	22
munition.....	4	20-mm Antiaircraft Cartridges.....	22
Scope.....	5	40-mm Antiaircraft Cartridges.....	24
Sources of Information.....	5	20-mm Aircraft Cannon Car-	
Reference Publications.....	5	tridges.....	25
2. NAVY GUN AMMUNITION.....	6	3-Inch and Larger Fixed Car-	
3-Inch and Larger Projectiles.....	6	tridges.....	25
3-Inch and Larger Armor-		Powder Bag Charges.....	26
Piercing (AP) Projectiles.....	7	Primers.....	28
3-Inch and Larger Common		Tracers.....	28
(Com) Projectiles.....	8	Color-Burst Units.....	29
3-Inch and Larger Antiaircraft		Auxiliary Boosters for Projec-	
(AA) Projectiles.....	8	tiles.....	30
3-Inch and Larger Antiaircraft		Lead Foil Envelopes.....	30
Common (AAC) and High-		Ammunition Information Cards	
Capacity (HC) Projectiles.....	10	for Single Depth Charge	
3-Inch and Larger Fuze-Cavity		Projector Impulse Cartridges.....	31
Liner (FCL(VT)) Projectiles.....	10	Ammunition Information Cards	
3-Inch and Larger Nonfrag-		for Torpedo Impulse Car-	
menting (FCL(VT) (Non-		tridges.....	31
Frag)) Projectiles.....	11	3. NAVY ROCKET AND PROJEC-	
3-Inch and Larger Target (BL		TOR CHARGE AMMUNITION.....	32
&P and BL&T) Projectiles.....	13	Rocket Heads and Motors and	
3-Inch and Larger Illuminating		Projector Charges.....	32
(Illum) Projectiles.....	13	Rocket Heads.....	33
3-Inch and Larger Chemical		Rocket Motors.....	34
Projectiles.....	14	Projector Charge Heads.....	34
3-Inch and Larger Window (W)		Projector Charge Tails.....	36
Projectiles.....	15	Rocket Motor Propellant	
Information for Cartridge		Grains.....	36
Cases.....	15	Rocket Motor Igniters.....	36
Cartridge Cases for 3-Inch and		Auxiliary Boosters for Rocket	
Larger Fixed Ammunition.....	16	Ammunition.....	36
Cartridge Cases for Semifixed		Projector Charge Cartridge	
Ammunition.....	19	Cases.....	38
Cartridge Cases for Single		4. UNDERWATER ORDNANCE... 40	
Depth Charge Projector Im-		Tags for Underwater Ordnance... 40	
pulse Cartridges.....	19	Mine Cases.....	40

*OP 2238 Identification of Ammunition - SAMPLE
(reduced size)-*

<i>Chapter</i>	<i>Page</i>	<i>Chapter</i>	<i>Page</i>
4. UNDERWATER ORDNANCE—		9. AMMUNITION CONTAINERS—	
Continued		Continued	
Depth Charge Cases.....	43	Projectile Boxes for Separate-	
Torpedo War Heads.....	44	Loading Chemical Projectiles.....	69
5. NAVY BOMBS.....	45	Projectile Boxes for 3-Inch and	
Navy Bombs.....	45	Larger Fixed Ammunition	
Armor-Piercing Bombs.....	45	Projectiles.....	71
General-Purpose (Low Drag)		Ammunition Boxes for 3-Inch	
Bombs.....	46	Fixed Cartridges.....	71
Depth Bombs.....	47	Ammunition Boxes for 20-mm	
Fire Bombs.....	48	Antiaircraft Cartridges.....	73
Miniature Practice Bombs.....	50	Ammunition Boxes for 40-mm	
Practice Bombs.....	50	Antiaircraft Cartridges.....	74
Bomb Fin Assemblies.....	51	Ammunition Boxes for Single	
Auxiliary Boosters for Bombs...	51	Depth Charge Projector Im-	
Practice Bomb Signals.....	52	pulse Cartridges.....	76
6. NAVY FUZES.....	53	Ammunition Boxes for Torpedo	
Navy Fuzes.....	53	Impulse Cartridges.....	77
Projectile and Rocket Fuzes...	53	Ammunition Boxes for Saluting,	
Bomb Fuzes.....	54	Blank, and Signal Gun Car-	
7. DEMOLITION MATERIAL.....	56	tridges.....	77
Demolition Material.....	56	Ammunition Boxes for Dummy	
Special Electric Blasting Caps..	56	Drill Cartridges.....	78
Demolition Charges.....	57	Cartridge Tanks for Explosive-	
Demolition Outfits (Haversack-		Loaded, Inert-Loaded Target,	
Packed).....	57	and Window Cartridges... 78	
Flotation Bladders.....	58	Cartridge Tanks for Illumi-	
8. PYROTECHNICS.....	60	nating Cartridges.....	81
Pyrotechnics.....	60	Cartridge Tanks for Chemical	
Aircraft Parachute Flares.....	60	Cartridges.....	83
Aircraft Emergency Identifica-		Cartridge Tanks for Semifixed	
tion Signals.....	61	Cartridges.....	85
Submarine Emergency Identifi-		Cartridge Tanks for Catapult	
cation Signals.....	62	Cartridges.....	87
Very Signal Lights.....	63	Cartridge Tanks for Short Car-	
Slick Marker Cartridges.....	63	tridges.....	88
Personnel Ejection Catapult		Powder Tanks for Powder Bag	
Cartridges.....	63	Charges.....	89
Target Identification Smoke		Powder Tanks for Replacement	
Bombs.....	64	Samples.....	91
9. AMMUNITION CONTAINERS... 67		Ammunition Tanks for Dummy	
Ammunition Containers.....	67	Drill Ammunition.....	92
Projectile Boxes for Separate-		Ammunition Tanks for Lead	
Loading Explosive-Loaded,		Foil.....	93
Inert-Loaded Target, and		Primer Containers.....	94
Window Projectiles.....	67	Fuze Containers.....	95
Projectile Boxes for Separate-		Color-Burst Unit Containers... 97	
Loading Illuminating Projec-		Rocket Head Shipping Boxes... 98	
tiles.....	68	Rocket Motor Shipping Boxes... 99	

**OP 2238 Identification of Ammunition - SAMPLE
(reduced size)-**

<i>Chapter</i>	<i>Page</i>	<i>Chapter</i>	<i>Page</i>
9. AMMUNITION CONTAINERS— Continued		10. ARMY-NAVY AMMUNITION— Continued	
Projector Charge Containers.....	101	Army 20-mm Aircraft Cannon Cartridges.....	111
Mine Crates.....	102	Grenades.....	112
Depth Charge Crates.....	103	Mortar Ammunition.....	113
Torpedo War Head and Exer- cise Head Containers.....	103	Army Artillery Ammunition.....	113
Bomb Crates.....	104	Army Aircraft Bombs.....	114
Bomb Tail Crates.....	104	Army Bomb Fuzes.....	115
Containers for Demolition Ma- terial.....	105	Primer Detonators.....	115
Containers for Pyrotechnics.....	106	Army Demolition Material.....	116
Bulk Black Powder Containers.....	107	Army Pyrotechnics.....	117
Bulk Smokeless Powder Boxes.....	109	Identification Information for Containers for Department of the Army Ammunition.....	118
Bulk High Explosives Con- tainers.....	109	Small-Arms Ammunition Con- tainers.....	118
10. ARMY-NAVY AMMUNITION.....	111	Army Bomb Containers.....	118
Army-Navy Ammunition.....	111		
Small-Arms Ammunition.....	111		

**NOTE: THIS MANUAL INCLUDES 15 PAGES OF COLOR
PLATES SHOWING MARKINGS, INCLUDING COLOR
SAMPLES**



Figure 29—Cartridge Case for Single Depth Charge Projector Impulse Cartridge.

**OP 2238 Identification of Ammunition - SAMPLE
(reduced size)-**

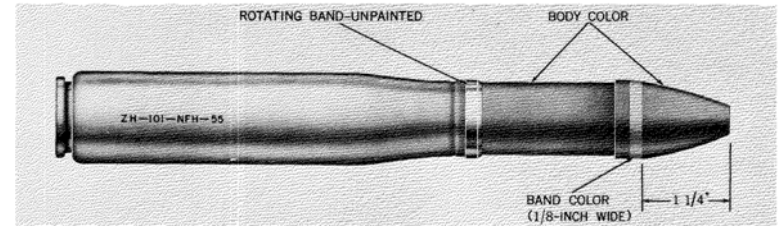

Figure 33—20-mm Antiaircraft Cartridges.

40-mm Antiaircraft Cartridges

Painting and Marking. The projectiles and the nose fuzes of 40-mm antiaircraft cartridges are painted with an identifying color to indicate the type of cartridge. Some projectiles

are marked with a circumferential band or bands for further identification. Only the area forward of the rotating bands is painted and marked. The projectiles are painted and marked in accordance with the following table and figure 34.

TYPE OF CARTRIDGE	BODY COLOR	BODY BAND	NOSE BAND	TIP COLOR
AP.....	Black	Black	Black	Black
APT.....	Black	Black	White	Black
HEP.....	Green	Green	Green	Green
HET-SD.....	Green	Green	White	Green
HEIT-SD.....	Green	Green	White	Red
HE-SD.....	Green	Green	Black	Green
HEI-SD.....	Green	Green	Black	Red
HEI-P.....	Green	Green	Red	Red
HEP-NP.....	Green	Green	Black	Black
HEIP-NP.....	Green	Green	Black	Black
HEIT-(DI)-SD.....	Green	Green	Yellow	Red
HEIT-NSD.....	Green	Black	White	Red
BL&P.....	Red	Red	Red	Red
BL&T.....	Red	Red	White	Red

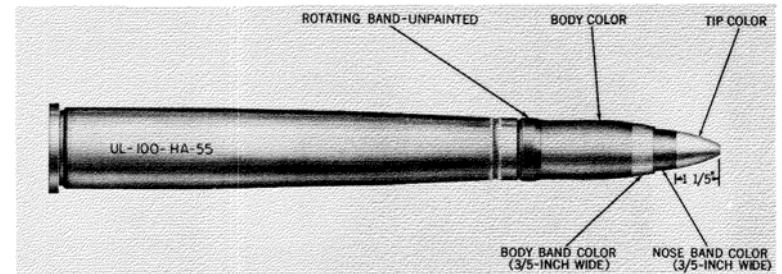

Figure 34—40-mm Antiaircraft Cartridges.

TM9-1300-203 Artillery Ammunition - SAMPLE
(reduced size)-

ARTILLERY AMMUNITION

CHAPTER 1. GENERAL	Paragraph	Page
Section I. Introduction	1-1, 1-2	1-1
Section II. General discussion	1-3-1-14	1-2-1-39
CHAPTER 2. GUN AND HOWITZER CANNONS		
Section I. General	2-1-2-3	2-1-2-6
Section II. Ammunition for 37-mm automatic gun M1A2	2-4-2-10	2-7-2-13
Section III. Ammunition for 37-mm subcaliber guns M12, M13, M14, M15 and M1916	2-11, 2-12	2-14
Section IV. Ammunition for 40-mm gun cannons M1, M1A1, M2, M2A1 and Mk1 (Navy)	2-13-2-22	2-16-2-24
Section V. Ammunition for 75-mm gun cannon M3	2-23-2-37	2-25-2-35
Section VI. Ammunition for 75-mm gun cannon M35 (T88E1)	2-38-2-42	2-35-2-37
Section VII. Ammunition for 76-mm gun cannons M32 and M48	2-43-2-54	2-37-2-46
Section VIII. Ammunition for 90-mm gun cannons M36, M41, M54 (T125) M1 series and M2 series	2-55-2-81	2-48-2-68
Section IX. Ammunition for 105-mm gun cannon M68	2-82-2-91	2-69-2-72
Section X. Ammunition for 120-mm gun cannons M1A1, M1A2 and M1A3	2-92-2-95	2-73-2-75
Section XI. Ammunition for 120-mm gun cannon M58	2-96-2-104	2-75-2-83
Section XII. Ammunition for 152-mm gun cannon M81	2-105-2-107	2-84-2-86
Section XIII. Ammunition for 155-mm gun cannons M2 and M46	2-108-2-116	2-87-2-94
Section XIV. Ammunition for 165-mm gun cannon XM135	2-117	2-95
Section XV. Ammunition for 175-mm gun cannon M113	2-118-2-121	2-95-2-101
Section XVI. Ammunition for 280-mm gun cannon M66	2-122-2-125	2-101-2-103
Section XVII. Ammunition for 75-mm pack howitzer cannon M1A1	2-126-2-136	2-104-2-109
Section XVIII. Ammunition for 75-mm pack howitzer cannon M1A1 used as a subcaliber weapon	2-137-2-139	2-109, 2-110
Section XIX. Ammunition for 105-mm howitzer cannons M2A1, M2A2, M4, M4A1, M49, M103 and M137	2-140-2-156	2-111-2-125
Section XX. Ammunition for 155-mm howitzer cannons M1, M1A1, M45 and M126	2-157-2-172	2-125-2-141
Section XXI. Ammunition for 8-inch howitzer cannons M2, M2A1, M2A1E1 and M47	2-173-2-176	2-141-2-147
CHAPTER 3. RECOILLESS RIFLES		
Section I. General	3-1-3-3	3-1, 3-2
Section II. Ammunition for 57-mm recoilless rifles M18, M18A1 and T15E16	3-4-3-14	3-3-3-9
Section III. Ammunition for 75-mm recoilless rifles M20 and T21E12	3-15-3-25	3-12-3-16
Section IV. Ammunition for 90-mm recoilless rifles M67	3-26-3-32	3-16-3-23
Section V. Ammunition for 105-mm recoilless rifles M27 and M27A1	3-33-3-38	3-23-3-26
Section VI. Ammunition for 106-mm recoilless rifles M40A1 and M40A1C	3-39-3-45	3-27-3-33
CHAPTER 4. MORTARS		
Section I. General	4-1, 4-2	4-1
Section II. Ammunition for 60-mm mortar cannons M2 and M19	4-3-4-12	4-2-4-14
Section III. Ammunition for 81-mm mortar cannons M1 and M29	4-13-4-29	4-16-4-38
Section IV. Ammunition for 4.2-inch mortar cannon M30	4-30-4-45	4-40-4-58
CHAPTER 5. FUZES		
Section I. General	5-1-5-9	5-1-5-12
Section II. Point-detonating (PD) fuzes	5-10-5-37	5-12-5-53
Section III. Point-initiating (PI) fuzes	5-38-5-41	5-54-5-57
Section IV. Mechanical time (MT) fuzes	5-42-5-50	5-57-5-69
Section V. Mechanical time and superquick (MTSQ) fuzes	5-51-5-58	5-71-5-89
Section VI. Time fuzes	5-59, 5-60	5-98, 5-94
Section VII. Time and superquick (TSQ) fuzes	5-61-5-63	5-96-5-100
Section VIII. Base-detonating (BD) fuzes	5-64-5-70	5-102-5-107
Section IX. Proximity (VT) fuzes	5-71-5-82	5-108-5-125
Section X. Dummy and inert fuzes	5-83, 5-84	5-126-5-130
Section XI. Boosters	5-85-5-91	5-131-5-136
CHAPTER 6. DESTRUCTION OF AMMUNITION TO PREVENT ENEMY USE		
	6-1, 6-2	6-1
APPENDIX REFERENCES		
		A-1
INDEX		
		I-1

TM9-1300-203 Artillery Ammunition - SAMPLE
(reduced size)-

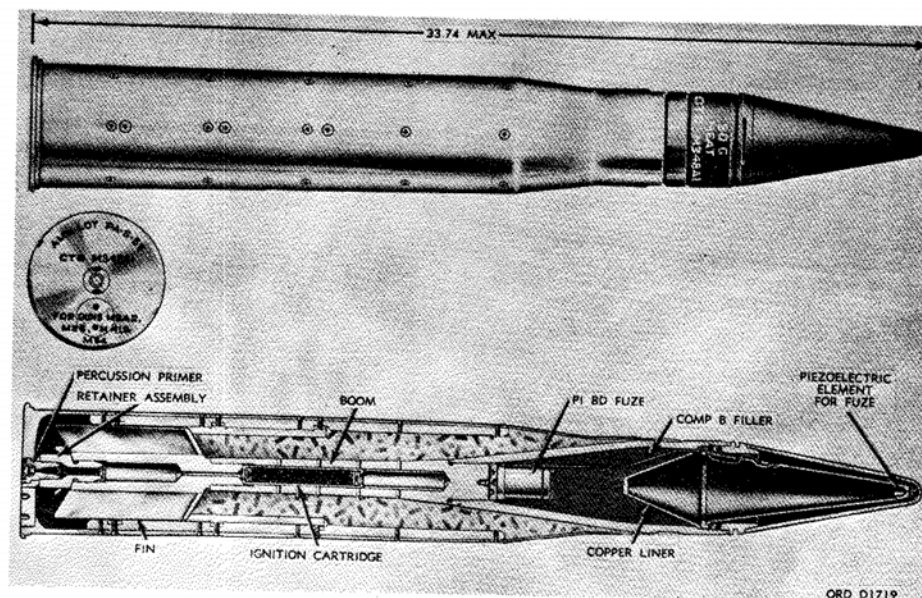

Figure 2-35. 90-mm HEAT cartridge M348A1.

c. *Functioning.* When the primer is struck, the flash it produces ignites the igniter assembly which, in turn, ignites the propelling charge. The force developed by the burning propellant breaks the retainer assembly and propels the projectile from the gun. On impact, the fin-stabilized projectile is detonated by fuze functioning and the copper cone collapses, creating a high velocity shock wave and a jet of metal particles which penetrate the target.

(3) *Components.*

Cartridge case	T27E2
Propellant	M6 (5 lb) M1 (5.4 lb)
Primer	T69
Igniter, Fin Assembly	T33E2

e. *Packing Data.* One round per fiber container; two containers per wooden box.

2-63. Cartridge, 90 Millimeter: HEAT, M348 (T108E40)

This cartridge is similar to cartridge M348A1 described in paragraph 2-62 above, except for the shape of the copper liner and the fin cross-section. The copper liner in the M348 is conical in shape with a tube extension attached to the smaller diameter of the cone; the M348A1 does not have this tube extension. The fin cross-section of the M348 car-

d. *Tabulated Data.*

(1) *Characteristics.*

Complete round with fuze:	
Weight (lb)	34.79
Length (in.)	33.74

(2) *Ballistics.*

Muzzle velocity (fps)	2,800
Maximum range (yd)	13,010

TM9-1300-203 Artillery Ammunition - SAMPLE
(reduced size)-

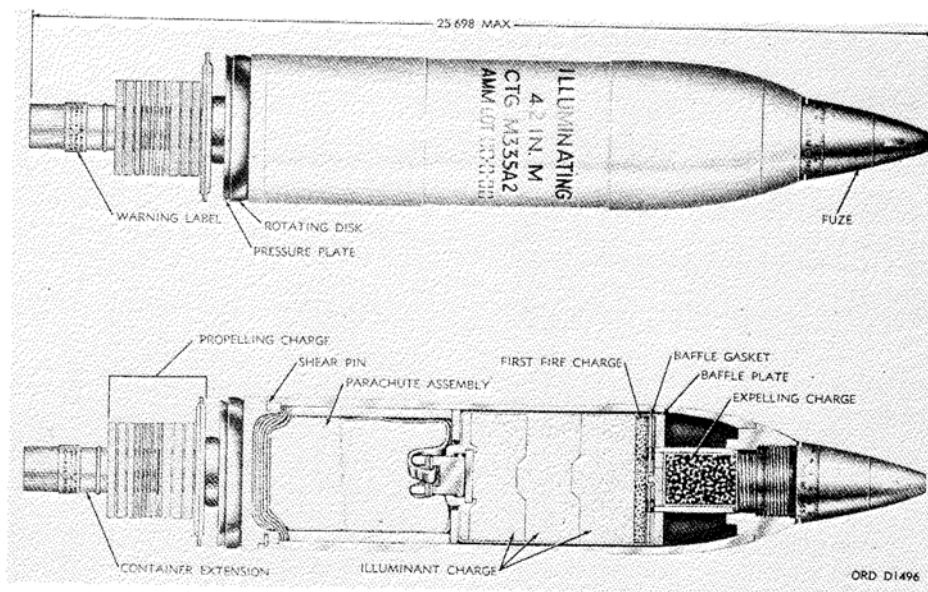

Figure 4-29. 4.2-inch illuminating cartridge M335A2.

c. **Functioning.** The fuze functions at a preset time in the projectile's flight, igniting the black powder in the expelling charge assembly. The gas pressure produced by the burning black powder is sufficient to shear the pins securing the base plate and eject the base plate, parachute assembly, illuminant canister and other internal components from the projectile. Concurrently, flames from the burning expelling charge travel through the baffle plate, baffle gasket, and base of the illuminating canister to ignite the first fire charge. The first fire charge, in turn, ignites the illuminant charge. While suspended by the parachute, the illuminant canister produces a luminosity of 850,000 candlepower for a minimum burning time of 90 seconds.

d. **Tabulated Data.**

(1) **Characteristics.**

Complete round with fuze:	
Weight (lb)	26.70
Length (in.)	25.70

(2) **Ballistics.**

Velocity (fps)	990
Range (yds)	5,782

(3) **Components.**

Propelling charge	M36A1
Ignition cartridge	M2A2

e. **Packing Data.** One cartridge per fiber container; multiple overpack in wooden box.

4-43. Cartridge, 4.2-Inch: Illuminating, M335A1

This cartridge is similar to cartridge M335A2 except that a different illuminant composition, an MT fuze, and an earlier version of the M2 ignition cartridge are used. The illuminant canister produces 500,000 candlepower and burns for approximately 70 seconds.

TM9-1300-203 Artillery Ammunition - SAMPLE
(reduced size)-

the case of fuzes of the M525-series apply (para 5-28).

Note. Rounds assembled with the A1 version of the fuze are authorized for training use only.

b. **Tabulated Data.**

Length:	
Overall (in.)	2.95
Intrusion (in.)	0.50
Weight (lb)	0.45
Thread size	1.5-12NF-1

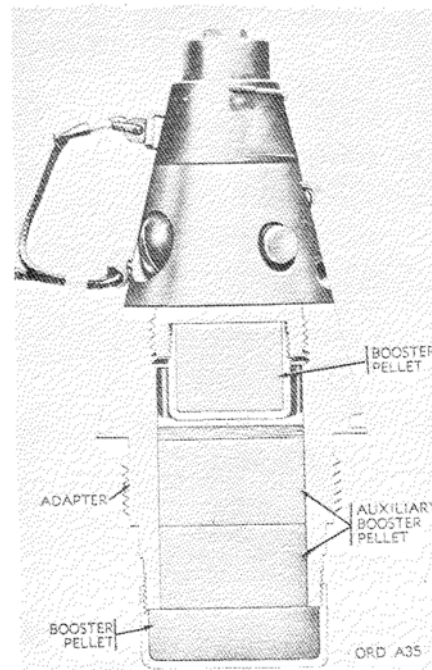

Figure 5-27. Point detonating fuze M526A1.

b. **Tabulated Data.**

Length, overall (in.)	5.88 (max)
Length, intrusion (in.)	2.21 (max)
Weight (lb)	1.19
Thread size	2-12UNS-1A

5-30. Fuze, Point Detonating: M527A1, M527 or M527B1 and M527A1B1

a. **General.** These fuzes (figs. 5-28 and 5-29) replace M82 series fuzes. They are similar to M525-series fuzes (para 5-28) except that M527-series fuzes have a smaller booster charge and an intrusion. They are for use with burster M19 in 60-mm WP smoke cartridge M302. The M527 and the M527A1 have a plastic body and the M527B1 and the M527A1B1 have an aluminum body. The same preparation for firing and precautions as in

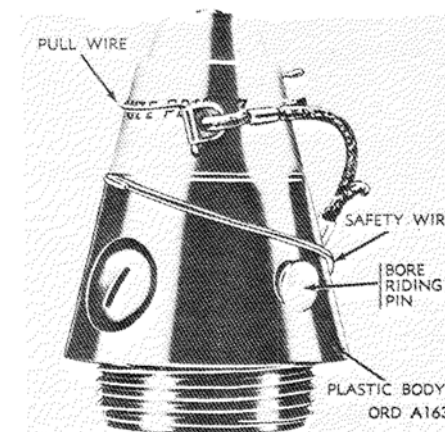

Figure 5-28. Point detonating fuze M527.

TM9-1900 Ammunition, General - SAMPLE
(reduced size)-
AMMUNITION, GENERAL

	Paragraphs	Page
CHAPTER 1. GENERAL		
Section I. Introduction	1-3	2
II. General discussion	4-13	3
CHAPTER 2. EXPLOSIVE AND CHEMICAL AGENTS		
Section I. Propellants	14-21	33
II. Low explosives	22-24	42
III. High explosives	25-28	46
IV. Chemical agents	29-38	60
CHAPTER 3. BASIC TYPES OF AMMUNITION		
Section I. Small arms ammunition	39-63	68
II. Grenades	64-70	102
III. Artillery ammunition	71-89	114
IV. Bombs	90-98	156
V. Pyrotechnics	99-113	185
VI. Rockets	114-121	215
VII. JATOS	122-129	231
VIII. Land mines	130-137	237
IX. Demolition materials	138-143	260
X. Guided missiles	144-154	293
XI. Cartridge-actuated devices for aircraft use	155-162	299
APPENDIX REFERENCES		305
INDEX		311

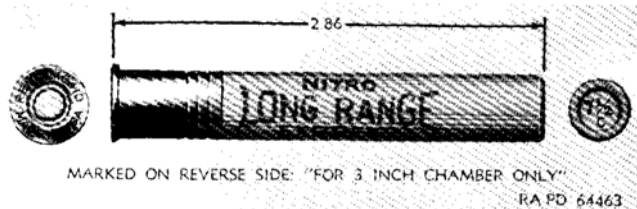

Figure 59. .410-gage paper shotgun shell.

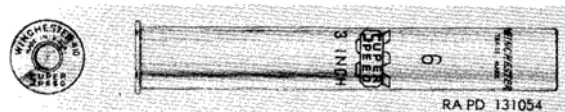

Figure 60. .410-gage aluminum shotgun shell.

from becoming broken or damaged. Broken boxes must be repaired immediately and careful attention given to the transfer of all markings to the new parts of the box. Metal liners and metal cans should be sealed and air-tested if equipment for this work is available.

b. *Preservation of Packings.* Ammunition boxes will not be opened until the ammunition is required for use, because ammunition from airtight containers, particularly in damp climates, may corrode and become unserviceable.

TM9-1900 Ammunition, General - SAMPLE
(reduced size)-

tridge (lead bullet) (fig. 28), which is the rimfire cartridge of commercial trade.

55. Subcaliber

Ball cartridge, caliber .22, long rifle (lead bullet) (fig. 28), is used in the caliber .22 interior mount subcaliber rifle M2A1 to subcaliber the 57-mm gun M1. Ball cartridge, caliber .30, M2 (fig. 29), is used in the caliber .30 interior mount subcaliber rifle M1903A2 to subcaliber the 57-mm gun M1. Ball cartridge, caliber .50, M2 (fig. 31), is used in heavy barrel caliber .50 machine gun M2 (flex) on exterior subcaliber mount to subcaliber the 76-mm gun of the M1 series and the 90-mm gun M3 (see TM 9-1901).

56. Grenade

Grenade cartridges (fig. 30) are special blank cartridges for use in propelling grenades and ground signals from launchers attached to rifles or carbines. Rifle grenade cartridges and carbine grenade cartridges are distinguished by a rose-petal crimp at the mouth of the case. The carbine grenade cartridge is no longer used by the Army for launching grenades but is authorized for blank fire for training purposes. For information pertaining to grenades, see paragraphs 64 through 70.

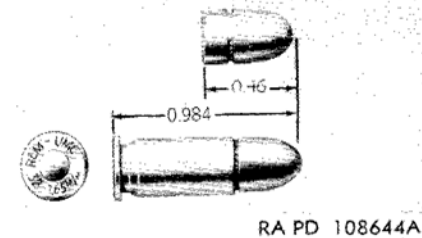

Figure 41. Caliber .32 ball cartridge.

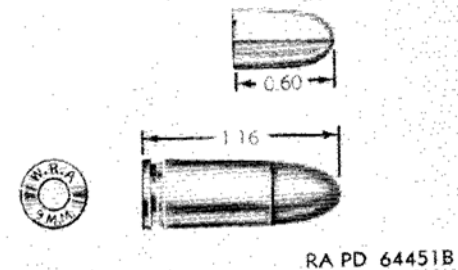

Figure 42. 9-mm ball cartridge.

TM9-1981 Military Pyrotechnics - SAMPLE
(reduced size)-

	Paragraph	Page
CHAPTER 1. GENERAL		
<i>Section I.</i> Introduction	1-9	1
<i>II.</i> Data	2-12	15
CHAPTER 2. FLARES		
<i>Section I.</i> Aircraft flares	13-19	31
<i>II.</i> Ground flares	20-24	55
<i>III.</i> Miscellaneous flares	25-27	69
CHAPTER 3. PHOTOFLASH CARTRIDGES		
CHAPTER 4. PYROTECHNIC BOMBS		
CHAPTER 5. FUZES		
CHAPTER 6. SIGNALS		
<i>Section I.</i> Signals for pyrotechnic pistols and projectors	45-51	104
<i>II.</i> Signals for grenade launcher	52-56	111
<i>III.</i> Drift signals and markers	57-59	122
<i>IV.</i> Distress signals	60-63	129
CHAPTER 7. PYROTECHNICS FOR TRAINING		
CHAPTER 8. DESTRUCTION OF PYROTECHNICS TO PREVENT ENEMY USE		
APPENDIX. REFERENCES		
INDEX		

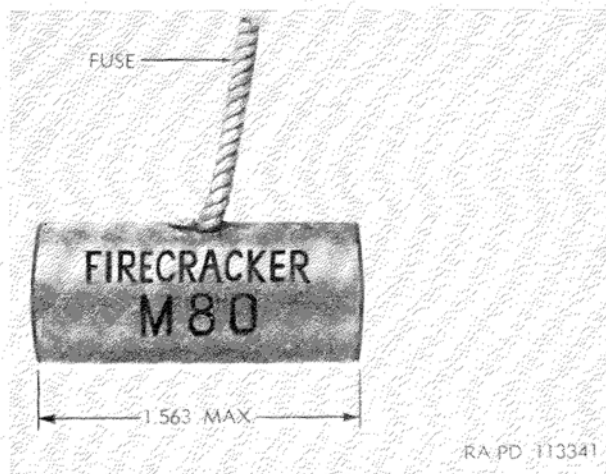
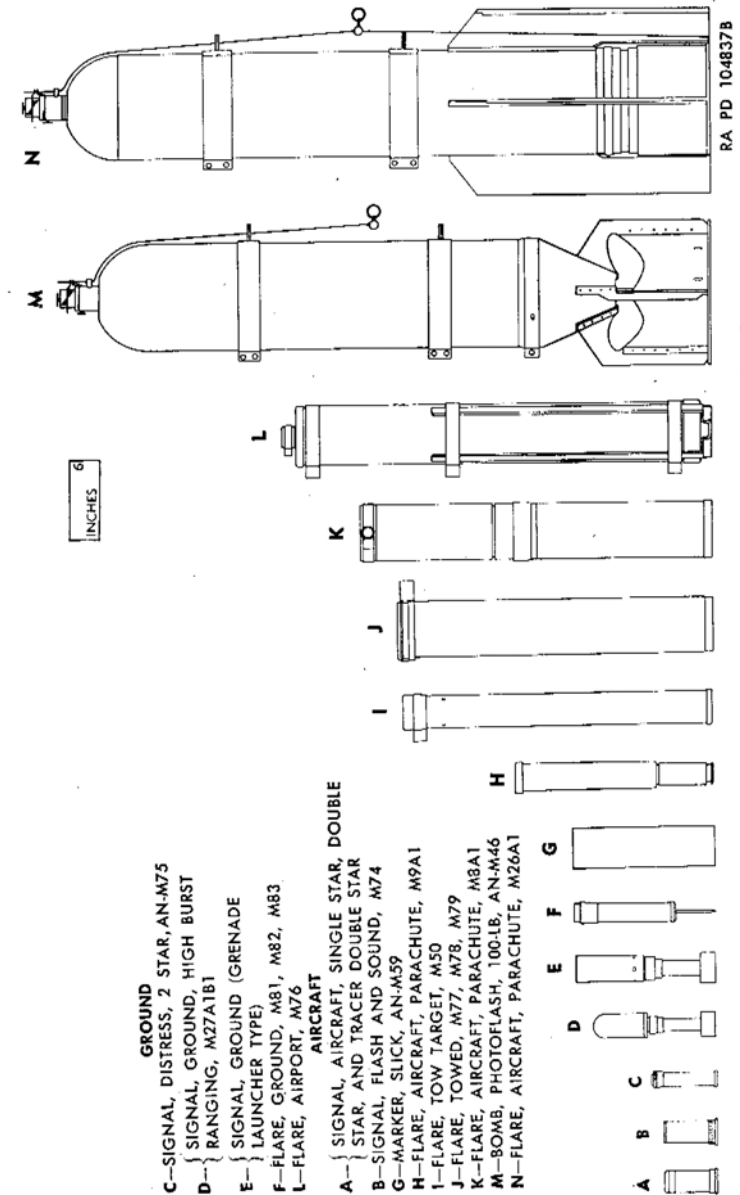

Figure 49. Firecracker, M80.

containing 3 grams of a potassium perchlorate, aluminum, sulfur, and antimony sulfide charge composition. The fuse, which is 2 inches long and burns for 3 to 7 seconds, is inserted into the side of the cylinder.

TM9-1981 Military Pyrotechnics - SAMPLE
(reduced size)-



- C**—SIGNAL, DISTRESS, 2 STAR, AN-M75
- D**—{ SIGNAL, GROUND, HIGH BURST
- { RANGING, M27A1B1
- E**—{ SIGNAL, GROUND (GRENADE
- { LAUNCHER TYPE
- F**—FLARE, GROUND, M81, M82, M83
- L**—FLARE, AIRPORT, M76
- AIRCRAFT**
- A**—{ SIGNAL, AIRCRAFT, SINGLE STAR, DOUBLE
- { STAR, AND TRACER, DOUBLE STAR
- B**—SIGNAL, FLASH AND SOUND, M74
- G**—MARKER, SLICK, AN-M59
- H**—FLARE, AIRCRAFT, PARACHUTE, M9A1
- I**—FLARE, TOW TARGET, M50
- J**—FLARE, TOWED, M77, M78, M79
- K**—FLARE, AIRCRAFT, PARACHUTE, M8A1
- M**—BOMB, PHOTOFLASH, 100-LB., AN-M46
- N**—FLARE, AIRCRAFT, PARACHUTE, M26A1

Figure 1. Military pyrotechnics—types and comparative sizes.

RA PD 104837B

RA PD 113341

*U.S. Bombs, Fuzes & Pyrotechnics - SAMPLE
(reduced size)-*

*U.S. Bombs, Fuzes & Pyrotechnics - SAMPLE
(reduced size)-*

SECTION I HIGH EXPLOSIVE BOMBS

INTRODUCTION	2
PART I: U.S. ARMY "MODIFIED MARK" SERIES BOMBS	
1000 lb. Mk I M IV	5
300 lb. Mk I M II	5
600 lb. Mk I M III	5
1100 lb. Mk III M I	5
2000 lb. Mk I, M I, M III, M IV, M V	5
PART II: U.S. ARMY "M" SERIES BOMBS	
INTRODUCTION	8
M5 30 lb. Frag	9
DEMOLITION - H.E.	
100 lb. M30	11
300 lb. M31	11
600 lb. M32	11
1100 lb. M33	11
2000 lb. M34	11
ARMOR-PIERCING - H.E.	
600 lb. M62	13
800 lb. M61	13
900 lb. M60	13
1000 lb. M52	13
1400 lb. M63	13
PART III: U.S. NAVY "MK." SERIES BOMBS	
GENERAL PURPOSE BOMBS	
100 lb. Mk 4, Mk 1	17
500 lb. Mk 12	19
1000 lb. Mk 13	21
DEPTH	
650 lb. Mk 29, Mk 37	23
650 lb. Mk 38, Mk 49	25
FRAGMENTATION	
30 lb. Mk 5	27
ANTI-AIRCRAFT	
5 lb. Mk 34	29
BOMB CONTAINER Mk 3	
	31
PRACTICE	
	33
PART IV: U.S. ARMY-NAVY "AN" SERIES BOMBS	
INTRODUCTION	36
EXPLOSIVES	40
GENERAL PURPOSE	
100 lb. AN-M30A1, AN-M30	45
150 lb. T1	47
250 lb. AN-M57A1, AN-M57	48
500 lb. AN-M43	51
500 lb. AN-M64	51
1000 lb. AN-M44	53

GENERAL PURPOSE - continued.	
1000 lb. AN-M65	53
1000 lb. VB-1 "Azon"	55
1000 lb. VB-3 "Razon"	57
2000 lb. AN-M34	59
2000 lb. AN-M66	59
12000 lb. T10	61
22000 lb. T14	63
LIGHT CASE	
2000 lb. T9	65
4000 lb. AN-M56	67
SEMI ARMOR-PIERCING	
500 lb. AN-M68A2	69
1000 lb. AN-M59A1, AN-M59	69
2000 lb. M103	71
ARMOR PIERCING	
1000 lb. AN-Mk 33	73
1600 lb. AN-Mk 1	73
DEPTH	
325 lb. Mk 17	75
350 lb. Mk 41	75
350 lb. Mk 44	75
350 lb. Mk 47	75
325 lb. AN-Mk 53 Mod 1, Mk 53	77
350 lb. AN-Mk 54 Mod 1, Mk 54	77
AIRCRAFT LAID MINES	
Mk 13	79
AN-Mk 26 Mod 1	81
FRAGMENTATION	
4 lb. M83	83
Cluster Adapters M15, M16	87
20 lb. AN-41	87
23 lb. AN-40	89
20, 23 lb. Clusters, Cluster Adapters	91
80 lb. M82	93
120 lb. M86	95
250 lb. AN-M88, M81	97

SECTION II INCENDIARY AND CHEMICAL BOMBS

INTRODUCTION	100
2 lb. Incend. AN-M52	103
4 lb. Incend. AN-M50	105
4 lb. Incend. AN-M54	107
6 lb. Incend. AN-M69	109
10 lb. Incend. M74	111
10 lb. Smoke M77	113
Cluster Adapter E6R2	115
Cluster Adapter M10A1	117
Cluster Adapter M23	119
50 lb. Floating Smoke Mk 1	121
100 lb. Floating Smoke Mk 3	121
100 lb. Incend. Mk 28	123
100 lb. Chemical Mk 42	125
100 lb. Chemical AN-M47A2	127
115 lb. Chemical M70	129
Fire Bombs	
500 lb. Incend. AN-M76	131
500 lb. Chemical AN-M78	133
1000 lb. Chemical AN-M79	136

SECTION III BOMB FUZES

INTRODUCTION	140
M1	149
AN-M100A2, AN-M101A2, AN-M102A2	151
M160, M161, M162	153
T75, T75E2	155

*U.S. Bombs, Fuzes & Pyrotechnics - SAMPLE
(reduced size)-*

BOMB FUZES - continued.

AN-M103	157
AN-M103A1	159
AN-M139A1, AN-M140A1, M139, M140	161
M148	163
M163, M164, M165	165
AN-M104, M109	167
AN-M120A1, AN-M120, M170	169
M105	171
M106A2	173
M108	175
M110, AN-M126A1	177
M158, M159	179
M111A2, M127, M158	181
AN-M128, AN-M145, AN-M146, AN-M147	183
M135, M135A1, M156, M136A1	185
M144	187
M152, M153	189
M155	191
M112A1, M113A1, M114A1	193
M115, M116, M117	195
M151	197
M123, M124, M125	199
M123A1, M124A1, M125A1	201
M132, M133, M134	203
M129	207
M130	209
M131	211
M142, M142A1	213
M150	215
M154	217
M157	219
M149	221
INTRODUCTION TO VT FUZES	222
T50E4, T50E1, T89, T90	226
T91, T92	227
M166	229
T82	231
Mk 3	233
AN-Mk 219	235
Mk 221, Mk 239	237
Mk 223	239
AN-Mk 228	241
AN-Mk 224	243
AN-Mk 234	245
Mk 227	247
Mk 229, AN-Mk 230	249
Mk 229 Mod 3, AN-Mk 230 Mods 4, 5, 6	251
Mk 231, Mk 240	253
Mk 232	255
Mk 233	257
Mk 237, Mk 238	259
Mk 243, Mk 244	261
British No. 68	263

*U.S. Bombs, Fuzes & Pyrotechnics - SAMPLE
(reduced size)-*

SECTION IV PYROTECHNICS

INTRODUCTION	266
PART I: AIRCRAFT PYROTECHNICS	
Red Star Aircraft Parachute Signal M11	270
Double Star Aircraft Signal AN-M28 to AN-M33	271
Aircraft Signal AN-M37 to AN-M42	272
Single Star Aircraft Signal AN-M34 to AN-M36	273
Single Star Aircraft Signal AN-M43 to AN-M45	273
Two Star Signal Cartridge Mk 3	273
Aircraft Signal AN-M53 to AN-M58	273
Signal Cartridge Mk 4	274
Very Signal Light Mk 2	275
Aircraft Emergency Identification Signal Mk 6	277
Aircraft Emergency Identification Smoke Signal	277
Night Drift Signal AN-Mk 4, AN-Mk 5	279
Aircraft Float Light Mk 6	279
Day Depth Charge Marker Mk 1	281
Night Depth Charge Marker Mk 2	283
Day Drift Signal AN-Mk 1	284
Miniature Practice Bomb Signal AN-Mk 4	284
Slick Marker Cartridge AN-Mk 1	285
Slick Marker AN-M59	285
White Smoke Grenade AN-M8	287
Aircraft Smoke Signals T43 to T47	289
Two Red Star Distress Signal T49	291
Single Red Star Distress Signal	291
Aircraft Engine Starter Cartridge	292
Aircraft Parachute Flare Mk 1	293
Flare Mk 4	295
Flare Mk 5	297
Flare Mk 6	299
Aircraft Flare Container	301
Flare AN-Mk 8	303
Flare Mk 10	305
Flare Mk 11	307
Flare AN-M26	309
Flare M24	310
Flare M8A1	310
Flare M9, M9A1	311
Tow Target Flare Mk 1	313
Tow Flares M77 - M79	313
Float Flare Mk 17	314
Photoflash Bomb M23A1	315
Photoflash Bomb AN-M46	317
Target Identification Smoke Bomb Mk 72	319
100 lb. Target Identification Bomb M84, M76	321
100 lb. Colored Smoke Streamer M87	323
250 lb. Target Identification Bomb M89, M90, M98	325
PART II: GROUND PYROTECHNICS	
Ground Signals M17 - M22	328
High Bursting Range Ground Signal M27	328
Ground Signals M17A1 - M22A1	329

U.S. Bombs, Fuzes & Pyrotechnics - SAMPLE
(reduced size)-

Smoke Ground Signal T38E1 - T42E1	331
Rocket Pistol Smoke Signal Mk 2	331
Hand Smoke Distress Signal Mk 1	332
Navy Red Light Mk 1	333
Navy Blue Light Mk 1	333
Parachute Trip Flare M48	336
Illuminating Hand Flare T14	336
Trip Flare M49	336
Tree Suspended Flare T25	337
Trip Wire Flare Mk 1	337
Ground Flare M81, M82, M83	338
Target Rocket Flare Mk 1	338
Illuminating Hand Grenade Mk 1	339
Airport Flare M13	340
Airport Flare M76	340
High Altitude Parachute Flare and Flare Mortar	341

PART III: SHIP AND SUBMARINE PYROTECHNICS

Ship's Emergency Identification Signals Mk 1,2,3,4	348
Submarine Emergency Identification Signal Mk 2, Mk 3	348
Submarine Float Signal Mk 1	349
White Rocket Mk 1	350
Rocket Pistol Signal Mk 1, Mk 3	351
Float Flare Mk 15	352
Submarine Emergency Identification Flare	353
Marine Marker T2	353
False Target Shell Mk 1	357
False Target Shell Mk 2	357

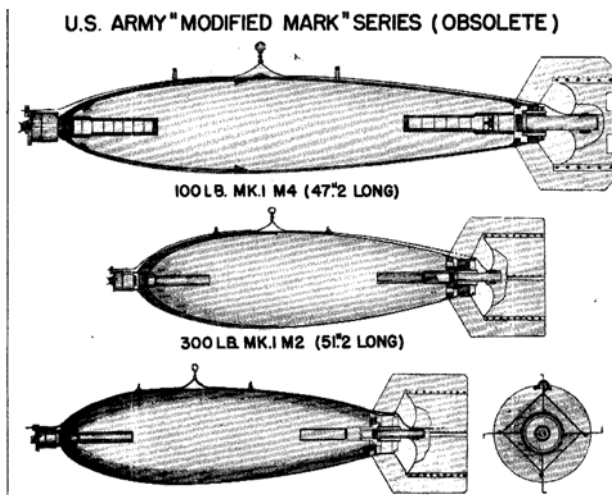

U.S. Bombs, Fuzes & Pyrotechnics - SAMPLE
(reduced size)-

RESTRICTED						U. S. ARMY BOMBS	
This particular series of bombs was not satisfactory for war use and has been abandoned, except for a few of these bombs which are being used at the present for target practice and training purposes. They are all of the same type and are intended for the same target use: Army Demolition H.E. bombs for General Bombardment. The following chart contains the essential data concerning the bombs of this series						"MODIFIED MARK" SERIES BOMBS (Obsolete)	
U. S. ARMY "MODIFIED MARK" SERIES BOMBS							
BOMBS	100 lb. Mk I MIV	300 lb. Mk I MII	600 lb. Mk I MIII	1100 lb. Mk-III MI	2000 lb. Mk I & M IV	2000 lb. Mk I & M IV	
FUZES	Nose: M105			Tail: M106			
OVERALL LENGTH	47.2"	51.2"	63.0"	68.5"	135.8"		
LENGTH OF BODY	39.5"	40.6"	52.2"	61.6"	97.0"		
BODY DIAMETER	7.9"	12.2"	16.5"	20.8"	18.5"		
WALL THICKNESS	0.16"	0.12"	0.2"	0.15"	0.50"		
WALL MATERIAL	Steel.						
BODY CONSTRUCTION	Streamlined body formed by welding three cast steel sections together.				Cast steel nose riveted to seamless steel tubing; rear not tapered.	Seamless steel tubing.	
TYPE OF SUSPENSION	Horizontal.						
CONSTRUCTION OF SUSPENSION	Two U-shaped bar steel eyebolts welded to body along longitudinal axis.				Two U-shaped eyebolts on plates secured to body by cap screws.		
COLOR & MARKINGS	Prior to March 11, 1942, these bombs would have been yellow all over with black manufacturer markings, but since that date will be olive-drab with one inch yellow bands around nose and base and a 1/4 inch band around center of gravity.						
LENGTH OF TAIL	8.5"	12.0"	14.0"	33.5"	49.2"		
WIDTH OF TAIL	11.0"	15.0"	20.5"	28.5"	26.1"		
MATERIAL OF TAIL	Sheet Steel				Sheet steel with cast steel tail cone.		
TAIL CONSTRUCTION	A cast steel sleeve secured to body by a fin locking nut; four fins or vanes; internal box-type struts.			Four vanes with bar struts, attached to body by screws.	Four vanes riveted to tail cone; two sets external bar struts to reinforce vanes. Cone secured to flange on base plate.		
WEIGHT OF TAIL	2.6#	6.1#	5.0#	55.0#	140.0#		
TYPE OF FILLING	Cast TNT						
WEIGHT OF FILLING	65.0#	148.0#	355.0#	650.0#	960.0#		
TOTAL WEIGHT	719.4#	285.9#	611.0#	1175.0#	1920.0#	1830.0#	
CHARGE/WEIGHT RATIO	54.5%	52.0%	58.0%	55.3%	50.0%	52.4%	

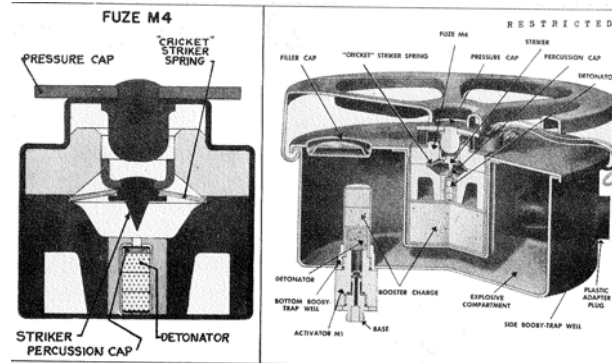

U.S. ANTI-TANK MINE M4

*U.S. Bombs, Fuzes & Pyrotechnics - SAMPLE
(reduced size)-*

*U.S. Bombs, Fuzes & Pyrotechnics - SAMPLE
(reduced size)-*

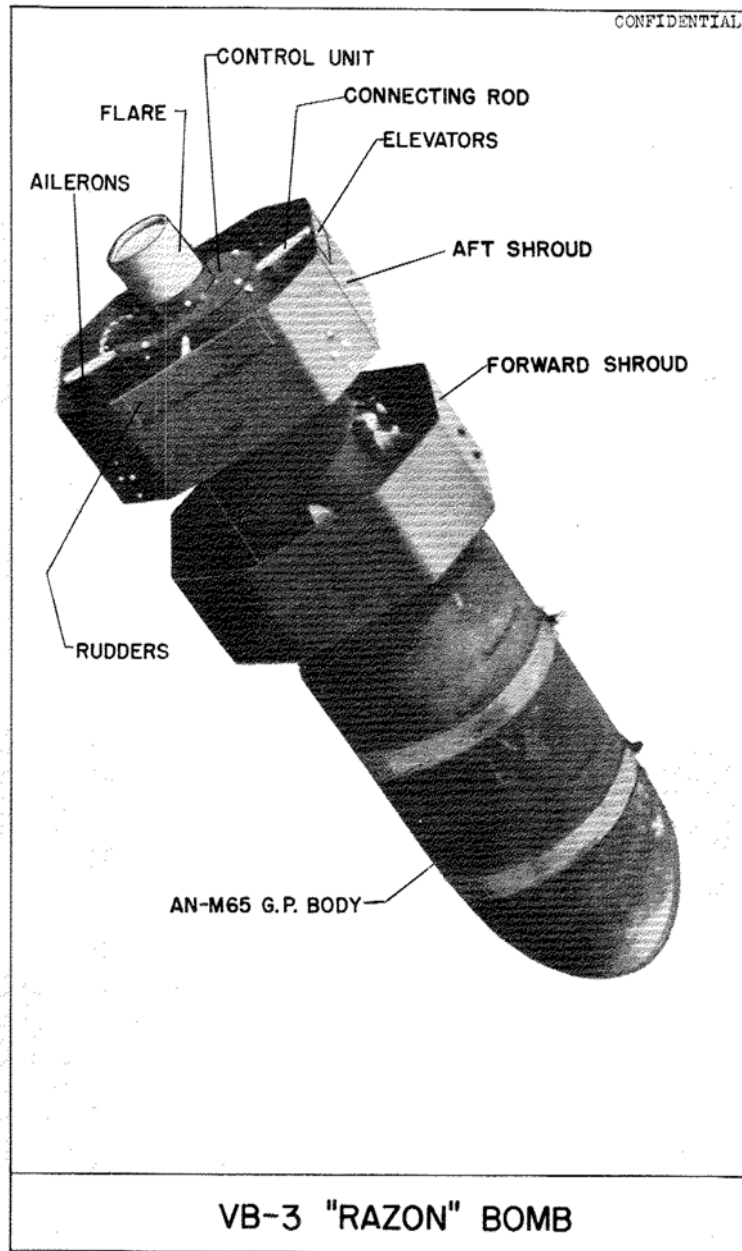

DATA:		<u>U. S. ARMY BOMB</u>	
OVERALL LENGTH	55.1 in.	1000 LB. VB-3	
BODY LENGTH	18.8 in.		
BODY DIAMETER	0.5 in.		
WALL THICKNESS			
TAIL LENGTH			
TAIL WIDTH			
TAIL WEIGHT		"Razon"	
WEIGHTS:			
	AN-M44 Body	AN-M65 Body	AN-M65A1 Body
Type of Filling	Amatol TNT	Amatol TNT	Amatol TNT
Weight of Filling	530# 558#	530# 558#	558# 595#
Total Weight			
Chg / Wt. Ratio			
FUZING:			
Nose:	AN-M103A1, AN-M103, M103, M139, M139A1, AN-M139A1, M140, M140A1, AN-M140A1		
Tail:	T75E2, M163, M164, M165		
BOMB CONSTRUCTION:			
<p>The VB-3 is a guided bomb similar to the VB-1 with the major difference that its flight may be controlled in range as well as in azimuth, and is known generally as the "Razon" bomb. Like the VB-1, it has special tail unit fitted to a 1000 lb. G.P. body, and is normally released from high altitude by use of a conventional bomb sight, the guided action being relatively small so that the trajectory at time of impact is essentially vertical.</p>			
TAIL UNIT:			
<p>The controls for the VB-3 are contained in the cylindrical section of the tail unit and consist of a radio receiver, a gyro, and a servo motor. Surrounding this unit are two shrouds; the forward shroud merely stabilizes the bomb in flight while the after one contains the elevators and rudders.</p> <p>On each of the four struts supporting the after shroud is an aileron controlled by the gyro. These four ailerons steady the bomb and prevent it from rotating while in flight. They are set 90° apart and operate in pairs, i.e. those ailerons placed opposite to each other move together in unison.</p> <p>The elevator and rudders located in the after shroud constitute the means for altering flight in azimuth and range. They operate in pairs in a manner similar to the ailerons, with the servo motor controlling their movements through connecting rods extending from the central unit. At present two bombardiers are required with the VB-3; one controls range and the other azimuth. They work independently of each other and by the use of a special bomb sight are always able to see the bomb in flight, superimposed on the target. As the bombardiers manipulate their control switches, radio signals are sent to the receiver; the receiver activates the servo motor which in turn moves the rudders and elevators, adjusting the flight of the bomb.</p> <p>As in the VB-1, flares are employed to assist the bombardier in the visual control of the flight of the bomb. Currently used flares are the T6E1 (white), T7E1 (red), and T8E1 (green) of 1,000,000 candlepower electrically ignited three to four seconds after release and with one to two minutes burning time. Mechanically-activated flares, T21, T22, and T23 are under development.</p>			
SUSPENSION:			
<p>Suspension lugs are welded to the case in a manner similar to the G.P. bombs. See Introduction, Page 37.</p>			
COLOR AND MARKINGS:			
<p>The Markings are similar to those of AN-M65 1000 lb. bombs. See Introduction, Page 37.</p>			
REMARKS:			
<p>The gyros must be started before the bomb is released.</p>			

**U.S. Bombs, Fuzes & Pyrotechnics - SAMPLE
(reduced size)-**

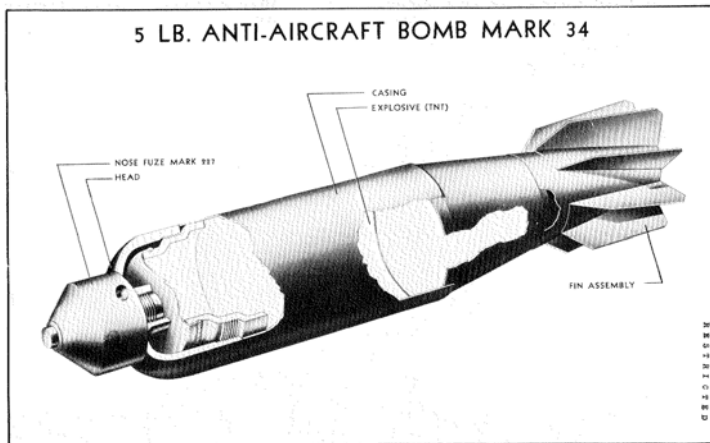

RESTRICTED

DATA:

OVERALL LENGTH	18.0 in.
BODY LENGTH	12.0 in.
BODY DIAMETER	3.0 in.
WALL THICKNESS05 in.
TAIL LENGTH	3.0 in.
TAIL WIDTH	3.0 in.
TAIL WEIGHT	3.0 in.

U. S. NAVY BOMB

5 LB. A.A.

Mk 34
(Obsolete)

WEIGHTS:

Type of Filling	T.N.T.
Weight of Filling	1.9 lbs.
Total Weight	5.5 lbs.
Chg / Wt. Ratio	34.5 %

FUZING: Mk 227 (Nose)

BODY CONSTRUCTION:	Reinforced steel nose and conical tail section welded to cylindrical steel body.
SUSPENSION:	Mk 3 or Mk 3 Mod 1 container (capacity 20 Mk 34 bombs).
COLOR & MARKINGS:	Grey or olive-drab overall. If grey, will have yellow disc on body; if olive-drab may have yellow nose band.
TAIL CONSTRUCTION:	Eight sheet steel vanes welded to tail cone which, in turn, is welded to body. Vanes are welded on cone at ten degree angle from the longitudinal axis.
REMARKS:	3 lb. Type C (Mk XXXII) A.A. bomb is a smaller copy of the 5 lb. bomb. It is no longer being used.

**U.S. Bombs, Fuzes & Pyrotechnics - SAMPLE
(reduced size)-**

RESTRICTED

U. S. NAVY

Date:

LENGTH	12.0 in.
DIAMETER	1.25 in.
BURNING TIME OF BLUE LIGHT	1 to 1.5 min.
BURNING TIME OF RED LIGHT	2.5 to 3 min.

NAVY RED LIGHT

Mk 1

NAVY BLUE LIGHT

Mk 1 Mod 1
(Hand Lights)

USE:

Flare suitable for hand use.

DESCRIPTION:

The flare consists of a paper tube filled with a pyrotechnic composition and attached to a wooden handle. The top of each flare contains a button of ignition material. A friction striker is provided with each signal.

OPERATION:

The flare is ignited by scraping the top of the inside cap against the forward end of the pyrotechnic mix. Hold the flare in an inclined position while burning to prevent drippings from burning the hand.

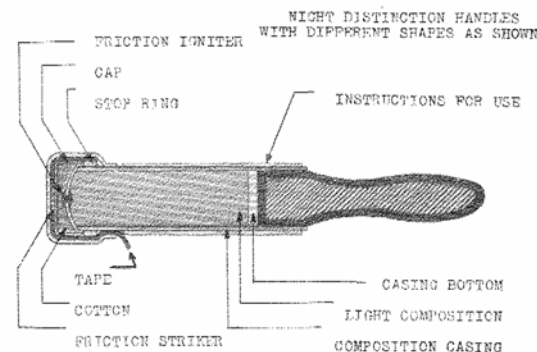
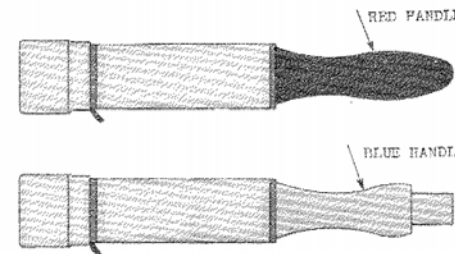

**NAVY RED LIGHT, MK I &
NAVY BLUE LIGHT, MK I, MOD I**

U.S. Bombs, Fuzes & Pyrotechnics - SAMPLE
(reduced size)-

<p>RESTRICTED</p> <p>Data:</p> <p>LENGTH 4.3 in. DIAMETER 2.1 in. WEIGHT 9.2 oz. INTENSITY OF LIGHT 60,000 candlepower DELAY 7 seconds BURNING TIME 25 seconds</p> <p>USE:</p> <p align="center">For illumination of enemy positions.</p>	<p>U. S. NAVY GRENADE</p> <p>ILLUMINATING HAND GRENADE</p> <p>Mk 1</p>
<p>DESCRIPTION:</p> <p>The grenade consists of two metal shells pressed together and sealed. The upper shell contains a Bouchon igniter and a delay fuze. The bottom shell contains the illuminant composition, first fire charge, ignition charge, quickmatch, and disc.</p>	
<p>OPERATION:</p> <p>Hold the grenade in the hand, making sure the lever is held tightly against the body of the grenade. Pull the release pin and throw the grenade. When the lever is released, the firing pin is freed to fire the primer. The primer ignites the delay which burns for 7 seconds and then ignites the ignition charge. The ignition charge sets off the first fire composition which in turn ignites the illuminant composition. The gases from the ignition charge and first fire force the two shells apart thus leaving the illuminant composition of the bottom shell free for burning.</p>	
<div style="display: flex; align-items: center;"> <div style="flex: 1;"> </div> <div style="flex: 1; padding-left: 20px;"> <p>ILLUMINATING HAND GRENADE MK 1</p> </div> </div>	

U.S. Bombs, Fuzes & Pyrotechnics - SAMPLE
(reduced size)-

<p>RESTRICTED</p> <p>Data:</p> <p>LENGTH OF BODY. 14.0 in. DIAMETER OF BODY. 1.5 in. BURNING TIME. 11 seconds INTENSITY OF LIGHT. 60,000 candlepower COLOR OF SINGLE STAR. Red, green, or yellow</p>	<p>U. S. NAVY SIGNAL</p> <p>ROCKET PISTOL SIGNAL</p> <p>Mk 1 COMET Mk 3 SHOWER CHAMELON</p>
<p>USE:</p> <p align="center">Used for emergency identification by surfaced submarines.</p>	
<p>DESCRIPTION:</p> <p>The upper section or signal chamber contains a pyrotechnic composition and powder ejector charge. The rocket motor, which is riveted to the signal chamber, contains one gram of black powder above a felt washer and 58 grams of black powder, which is the rocket element. Four spring loaded hinged vanes, 4 inches long and 1 inch wide, are attached to the rocket tube and fold and fit into the rocket chamber. The rocket chamber is an aluminum container with a Mk 5 primer in its base. This unit receives the rocket motor.</p>	
<p>OPERATION:</p> <p>The signal is fired from the Submarine Rocket Pistol or the Pyrotechnic Pistol AN-M8. Release of the trigger fires the primer which ignites the one gram auxiliary propelling charge. This black powder charge propels the signal chamber and attached rocket motor to about 30 feet from the pistol muzzle. At this point the 58 gram charge of black powder, which is the rocket element, takes effect and propels the signal to a height of approximately 650 feet. The rocket element ignites the expelling charge at the zenith of trajectory. The expelling charge ignites the star and simultaneously ejects it. The single star falls freely and burns out just before hitting the water.</p>	
<p>REMARKS:</p> <p>This signal replaces the chameleon type, Submarine Rocket Signal. The Rocket Pistol Signal Mk 3 Mod O (Shower) is similar to this signal except that a burst shower is produced instead of a single star. The Rocket Pistol Signal Chameleon is similar to this signal except that a variety of colors is obtained.</p>	
<div style="display: flex; justify-content: center; align-items: center;"> </div> <p align="center">PISTOL, ROCKET SIGNAL MK 1 (COMET)</p>	

U.S. Bombs, Fuzes & Pyrotechnics - SAMPLE
(reduced size)-

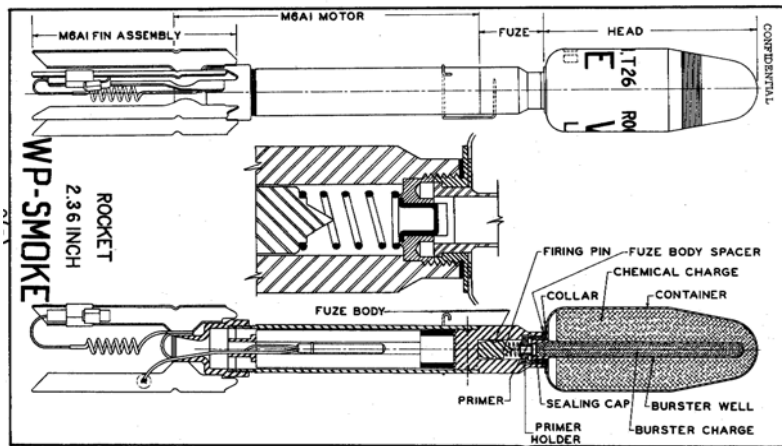

OVERALL LENGTH 19-5/16"
 TOTAL WEIGHT 3.4 lbs.
 LENGTH OF HEAD 5 1/4"
 MAX. DIAMETER 2.36"
 DIAMETER OF HEAD 2.30"
 WP CHARGE 405 gm.
 BURSTER CHARGE 4 gm.
 EFFECTIVE RANGE 300 yd.
 COLOR Motor: Olive drab
 Head: Blue grey

U. S. ARMY

**2.36 SMOKE
(W.P.) ROCKET**

M 10

TARGET: This rocket is designed not only as a screening agent, but also to cause casualties. WP in smoke form has little effect upon the human body, but particles cause small burns. This rocket makes an effective weapon for dislodging enemy troops from dug-outs and foxholes.

LAUNCHER: The M 10 rocket is fired from the 2.36 Rocket Launcher M1A1 or M9, commonly known as the "bazooka".

CONSTRUCTION: The components of this rocket are the motor assembly and the head assembly. The motors presently used are the M6A1 (see drawing) which is being replaced by the M6A3 (see motor on page 8). As new motors are developed, it is contemplated that this rocket will be modified.

The head assembly consists of a container for the smoke charge with a long burster well containing PETN inserted from its after end. A collar is soldered to the base of the container. The spacer slips over the threads of the collar and is held against the flat surfaces of the collar by the fuze body, forming a joint between the two. The primer holder is threaded into the fuze body.

TAIL ASSEMBLY: The M 10 rocket has the standard tail assembly for the M6A1 or M6A3 motors.

FUZING: The fuze is similar to that used in the M6A3 AT Rocket.

U.S. Bombs, Fuzes & Pyrotechnics - SAMPLE
(reduced size)-

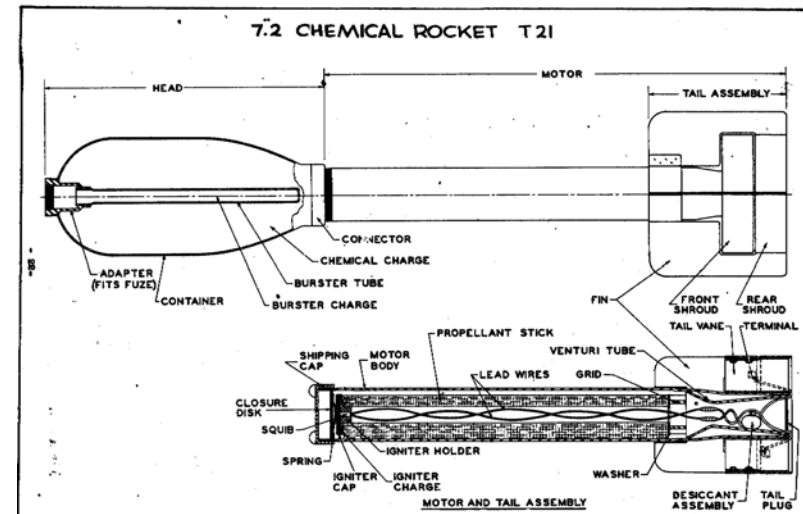

Motor Mk 5 and Body Mk 7

OVERALL LENGTH 48.1 in.
 BODY WIDTH 7.2 in.
 BODY LENGTH 18.75 in.
 MOTOR LENGTH 29.0 in.
 PROPELLANT Mk 11 ballistite grain
 PROPELLANT LENGTH 20.25 in.
 FILLER Any chemical filler with
 sp. gr. over 1.2
 FILLER WEIGHT (FS) 19.7 lbs.
 PROPELLANT WEIGHT 5.25 lbs.
 TOTAL WEIGHT 53.2 lbs.
 RANGE (approx.) 3500 yds.
 SERVICE TEMP. LIMITS 10° to 120° F.
 FUZING Mk 147 or Mk 147-1
 (nose)
 COLOR (head) Gray, with yellow nose band.
 COLOR (motor) Olive drab with nomenclature stencilled in yellow.

U. S. ARMY-NAVY

**7.2" CHEMICAL
ROCKET**

Navy: 772 CWR-N
 Army: 772 T 21

USE:
 Laying smoke screens or disseminating chemical agents among enemy troops.

LAUNCHER:
 This rocket is fired from a 24-rail demountable, variable-elevation launcher carried in a 2 1/2 ton truck. The salvo is fired in 2 1/2 seconds, and the launcher can be reloaded in 1 1/2 minutes.

GENERAL:
 These two rockets are identical, and are under production by the Army as the 772 T21 rocket, though the rocket is of Navy design and takes a Navy fuze. The only essential difference between the rockets as used by the Army and Navy is in the propellant, as is mentioned below.

CONSTRUCTION:
 The body consists of the container, adapter, burster tube, burster charge, chemical charge, shipping plug, and connector. The container is a bulb-shaped steel tube, open at both ends. The adapter fits inside the flange on the forward end of the container and is brazed thereto. The wide, forward end of the adapter is internally threaded to seat the fuze. The burster tube, made of steel, fits inside the adapter and extends downward into the container. The tube and adapter are held together by a press fit and sealed with white lead paste. The rear end of the tube is closed.

MOTOR:
 The motor is a steel tube, the forward end of which is externally threaded to screw into the connector of the head. The venturi tube, or nozzle is slipped down through the large, open end of the motor body, and the end is welded to the inner edge of the motor-body rim.